

BOSCH

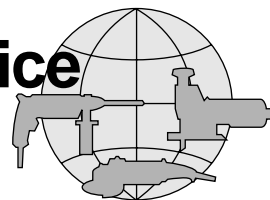

Service



EW / WJW 0 603 326 7.. (99 - 07) X

INSTANDSETZUNGSHINWEISE
REPAIR INSTRUCTIONS
INSTRUCTIONS DE REPARATION
INSTRUCCIONES DE REPARACION

Bohrhammer
Rotary Hammer
Marteau perforateur
Martillo perforador

Typ 0 603 326 7.. = PBH 240 RE

Änderungen vorbehalten. Unsere Erzeugnisse werden stets dem neuesten technischen Stand angepaßt. Deshalb behalten wir uns Änderungen vor.

Modifications. Our products are constantly modified to meet new technical standards. We therefore reserve the right to alter data and specifications without prior notice.

Modifications. Nos produits sont continuellement adaptés aux dernières nouveautés techniques et les dates sont données sous réserve de changement.

Modificaciones. Nuestros fabricados van siendo adaptos constantemente a las últimas conquistas técnicas. Por ello, tenemos que reservarnos el derecho de introducir modificaciones en los datos técnicos.

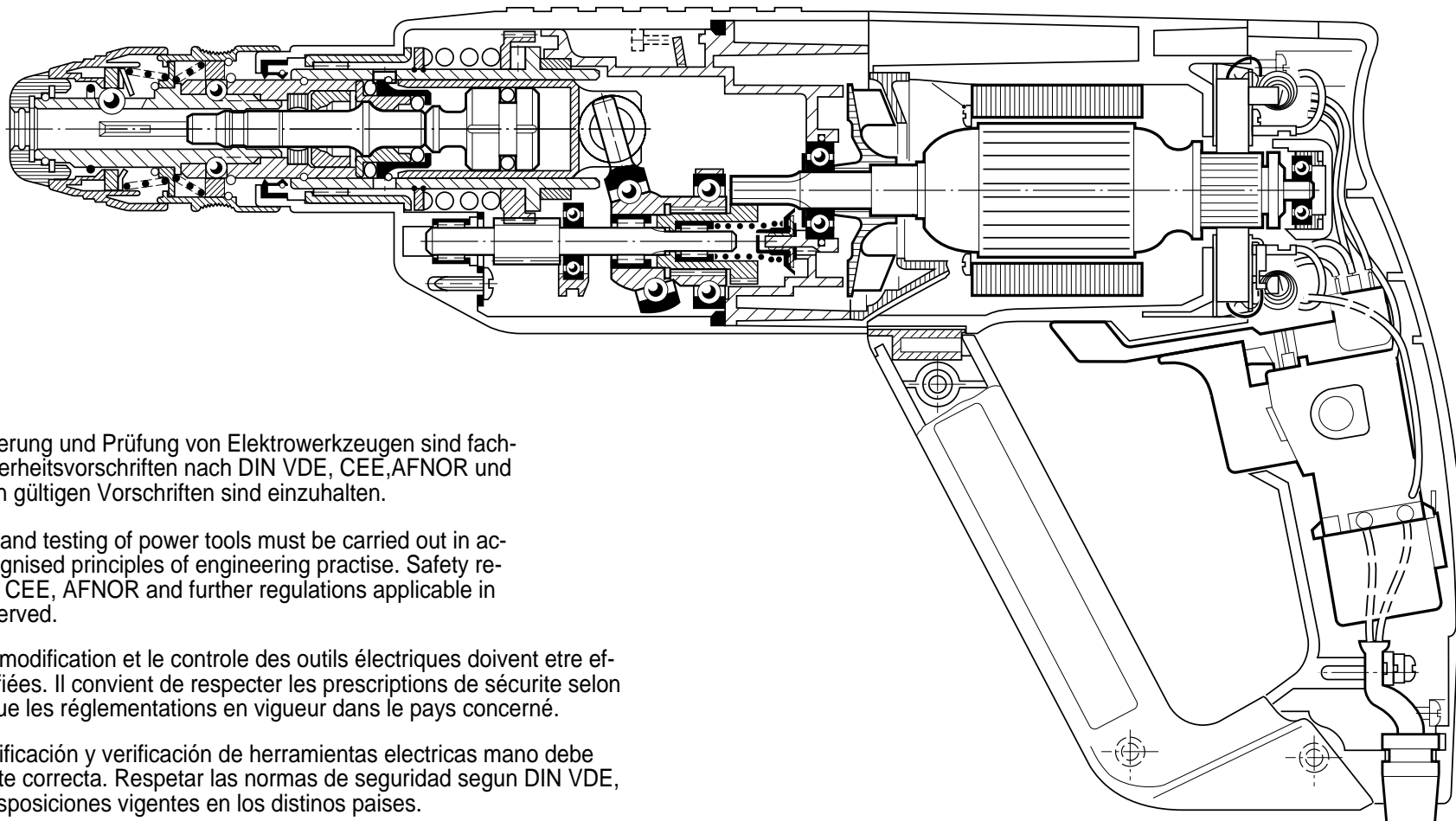

Beachten: Instandsetzung, Änderung und Prüfung von Elektrowerkzeugen sind fachgerecht durchzuführen. Die Sicherheitsvorschriften nach DIN VDE, CEE, AFNOR und weitere in den einzelnen Ländern gültigen Vorschriften sind einzuhalten.

Attention: Repair, modification, and testing of power tools must be carried out in accordance with the generally recognised principles of engineering practise. Safety regulations according to DIN VDE, CEE, AFNOR and further regulations applicable in individual countries must be observed.

Attention: La remise en état, la modification et le controle des outils électriques doivent être effectués par des personnes qualifiées. Il convient de respecter les prescriptions de sécurité selon DIN VDE, CEE, AFNOR, ainsi que les réglementations en vigueur dans le pays concerné.

Obsérvese: La reparación, modificación y verificación de herramientas electricas mano debe efectuarse en forma técnicamente correcta. Respetar las normas de seguridad segun DIN VDE, CEE, AFNOR, asi como otras disposiciones vigentes en los distintos paises.

ROBERT BOSCH GMBH GESCHÄFTSBEREICH ELEKTROWERKZEUGE D 70745 LEINFELDEN-ECHTERDINGEN



Typ 0 603 326 7..

Zerlegen

Für die Demontage werden handelsübliche Werkzeuge benötigt.

1. Eingangsprüfung durchführen.
Beachten:
Die Sicherheitsvorschriften nach DIN, VDE, CEE, AFNOR und weitere in den einzelnen Ländern gültigen Vorschriften sind einzuhalten.

Disassembly

Use normal trade tools by disassembly.

1. Carry out power supply check.
Attention:
Safety regulations according to DIN, VDE, CEE, AFNOR and further regulations applicable in individual countries must be observed.

Démontage

Pour le démontage, des outils en usage dans le commerce sont nécessaires.

1. Effectuer un contrôle préliminaire.
Attention:
Respecter les instructions de sécurité selon DIN, VDE, CEE, AFNOR et les autres instructions valables dans les pays respectifs.

Desmontaje

Para el desmontaje no se precisan herramientas especiales.

1. Realizar control de recepción.
Atención:
Atenerse a las prescripciones de seguridad según DIN, VDE, CEE, AFNOR y a las prescripciones adicionales específicas que pudieran existir en los respectivos países.

1.

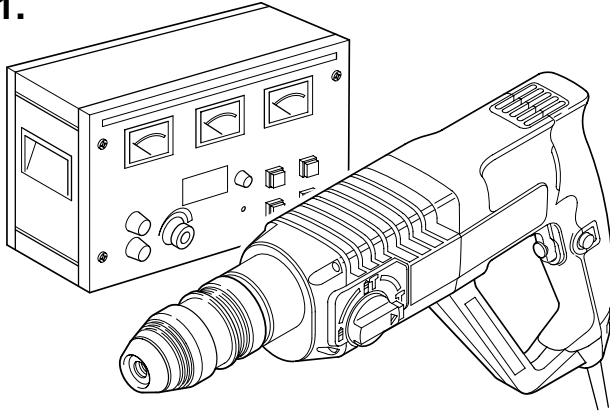

2.

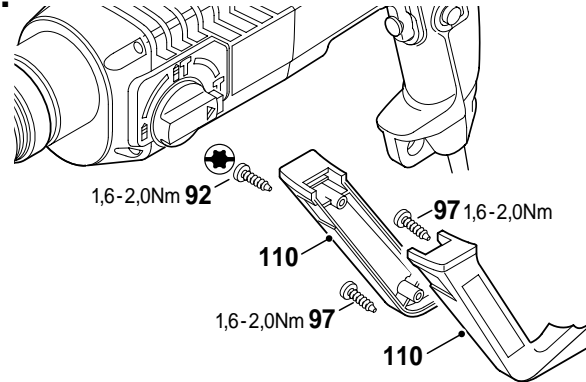

2. Zerlegen nach Explosions-, Schnittzeichnung und diesem Instandsetzungshinweis.
2. Disassembly using explosion, cut-away drawings and these repair instructions!
2. Démontez l'appareil suivant la vue éclatée, le plan en coupe et ces instructions de réparation.
2. Realizar el desmontaje conforme a los dibujos en perspectiva y en sección, y a estas instrucciones de reparación.

3.

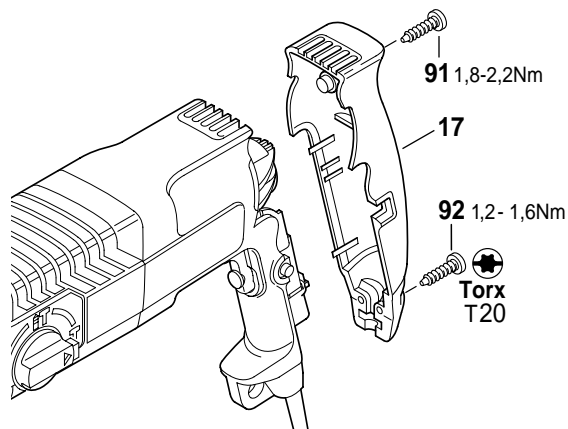

4.

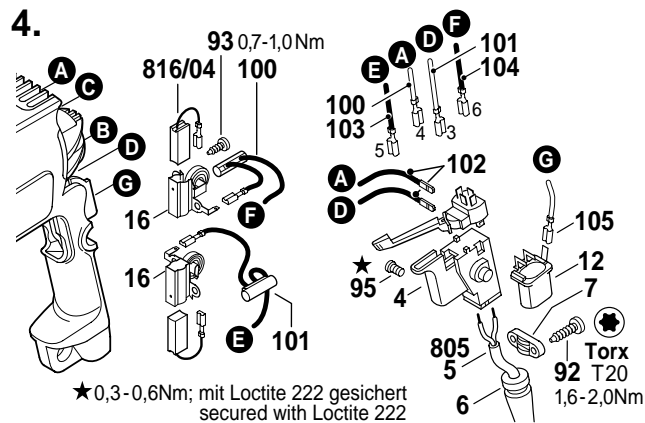

5.

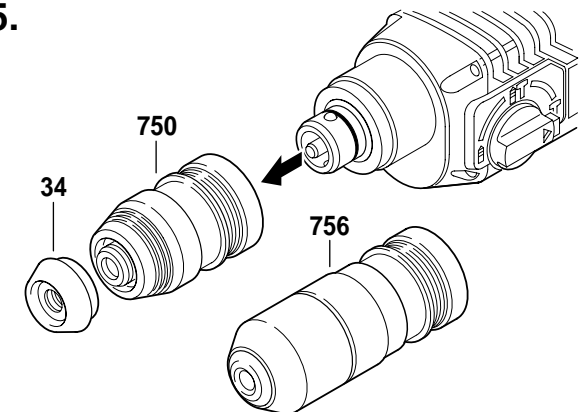

5.2

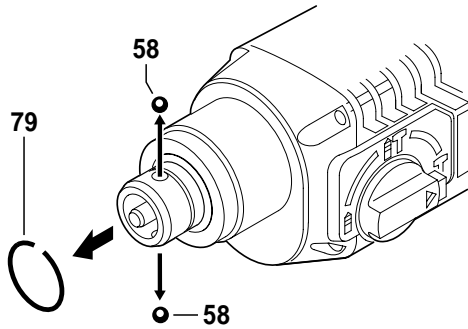

6.

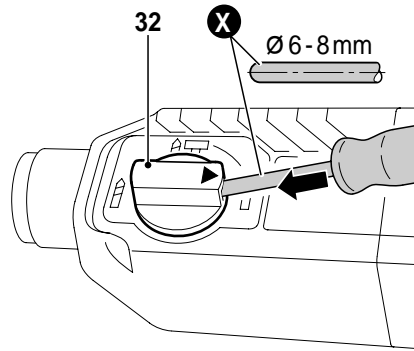

6.1

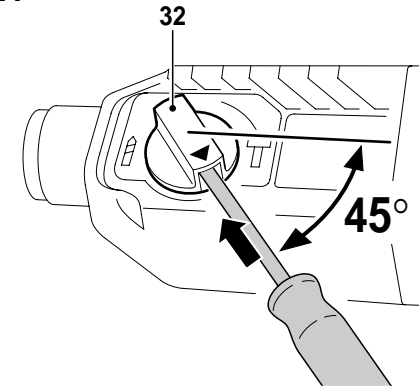

6.2

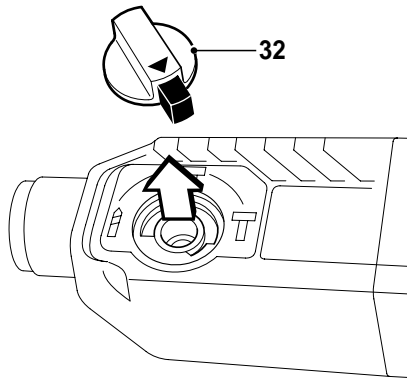

7.

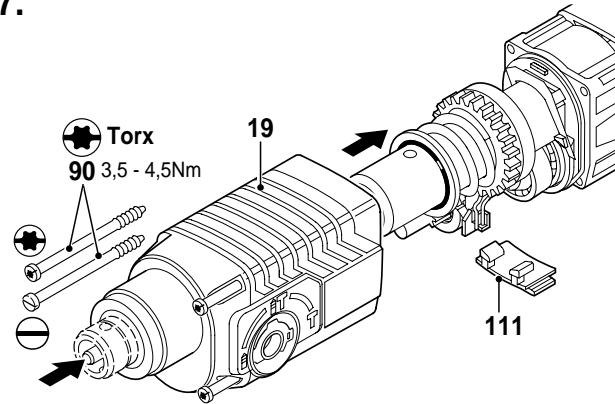

7.1

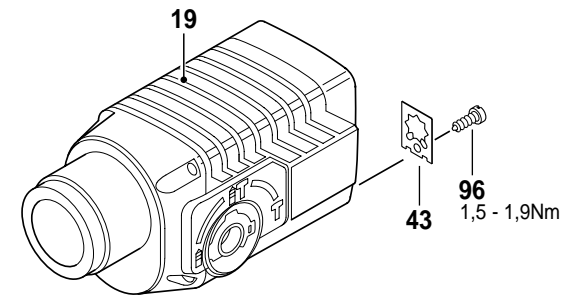

7.2

A Abziehvorrichtung
Extracting device
Dispositif extracteur
Dispositivo extractor

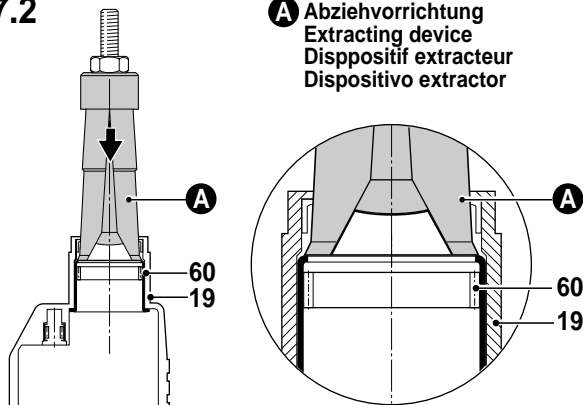

7.3

A Abziehvorrichtung
Extracting device
Dispositif extracteur
Dispositivo extractor

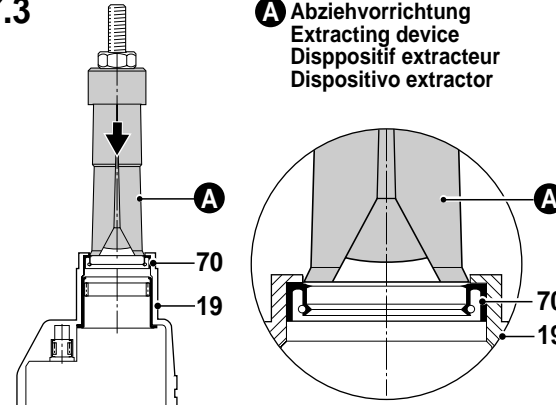

7.4

B Abziehvorrichtung
Extracting device
Dispositif extracteur
Dispositivo extractor

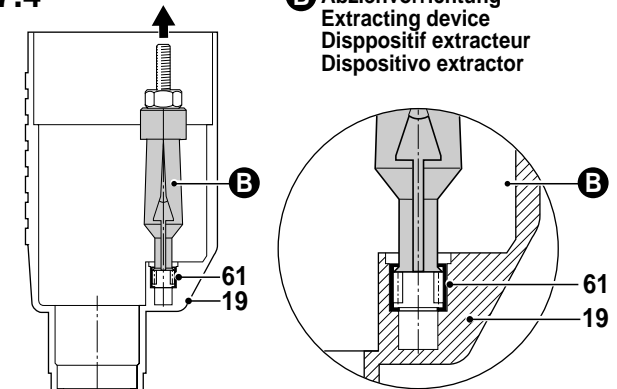

8.

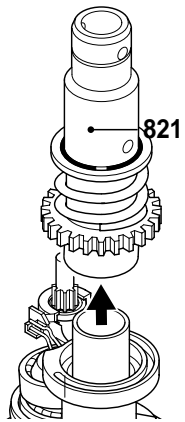

8.1

Ausrastmoment der der Sicherheitskupplung prüfen.
 Check release torque of safety clutch.
 Contrôler le moment de désaccouplement
 de l' accouplement de sécurité.
 Comprobar el par de desenganche
 miento del embrague de seguridad.

14 - 18 Nm

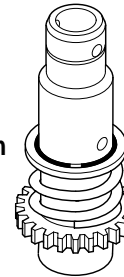

8.2

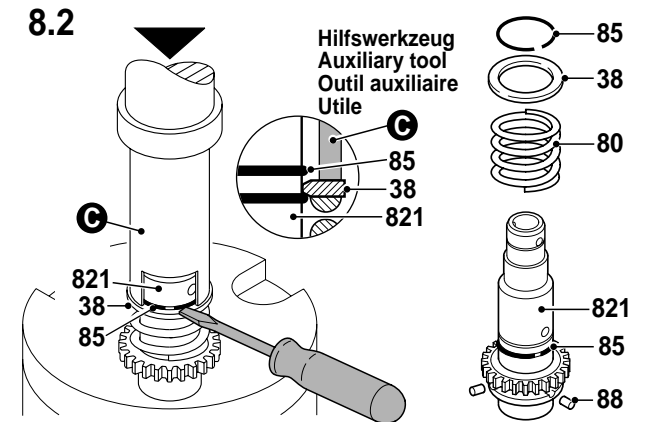

8.3

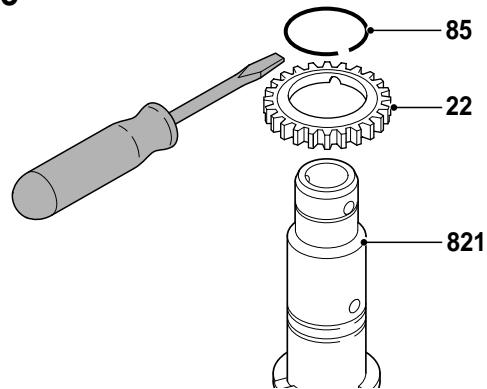

8.4

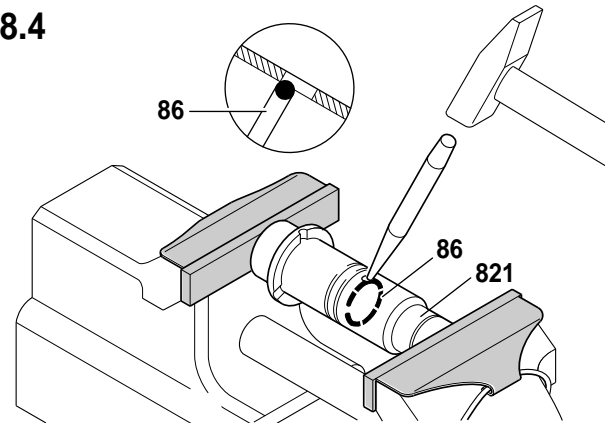

8.5

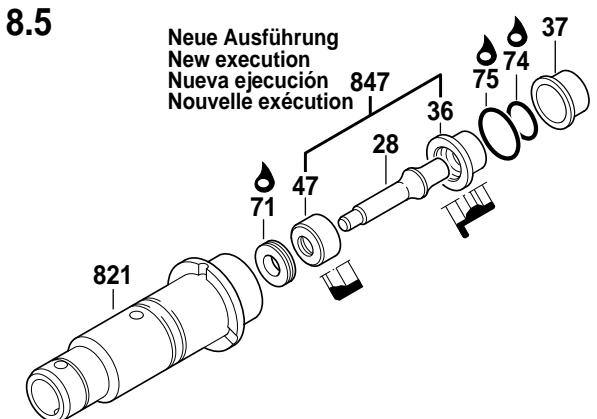

9.

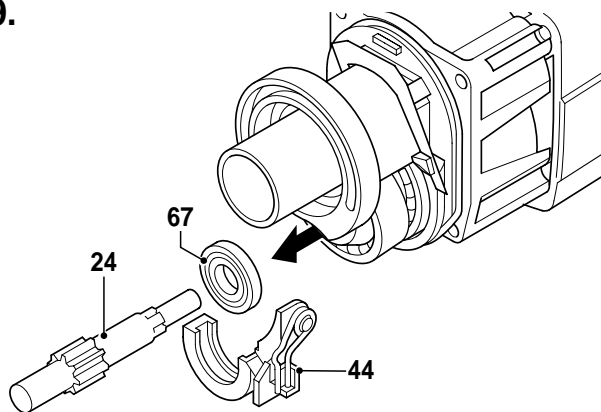

9.1

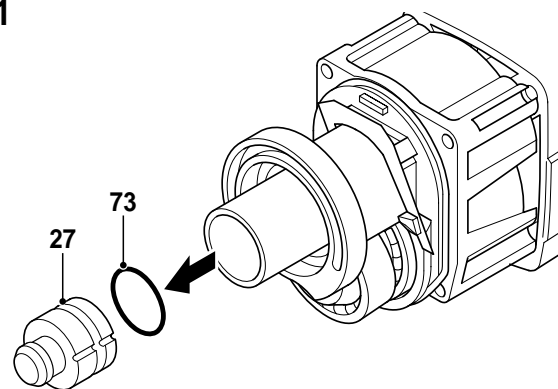

9.2

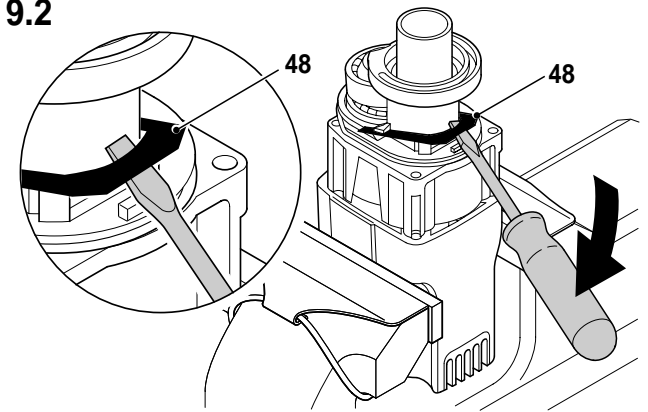

9.3

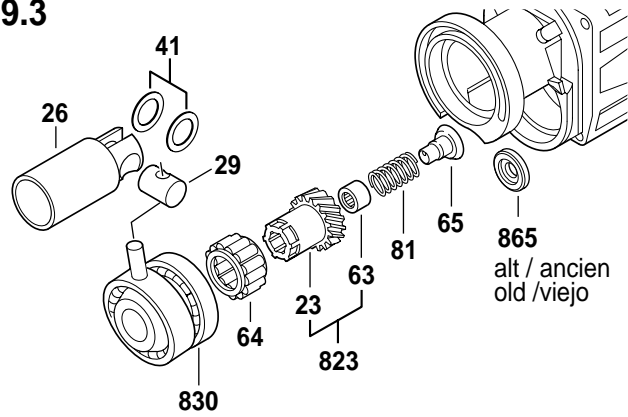

9.4

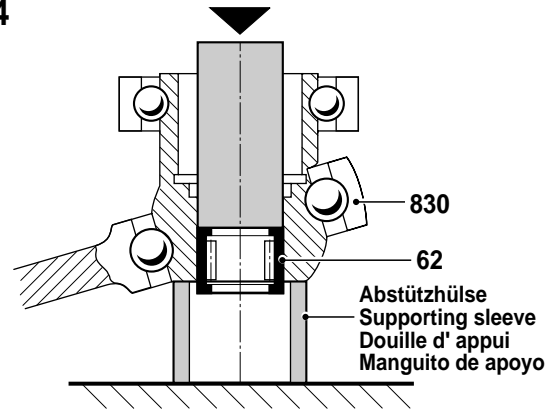

10.

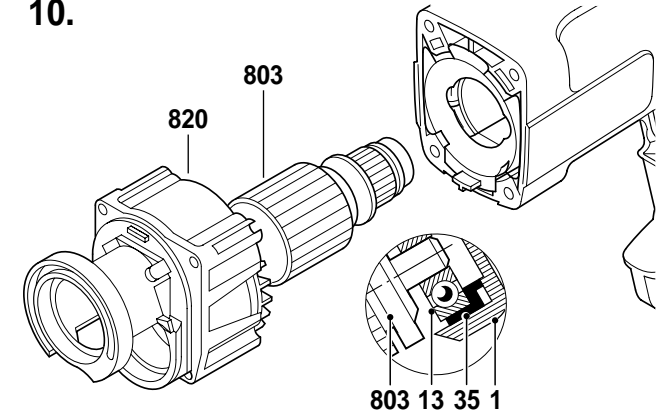

10.1

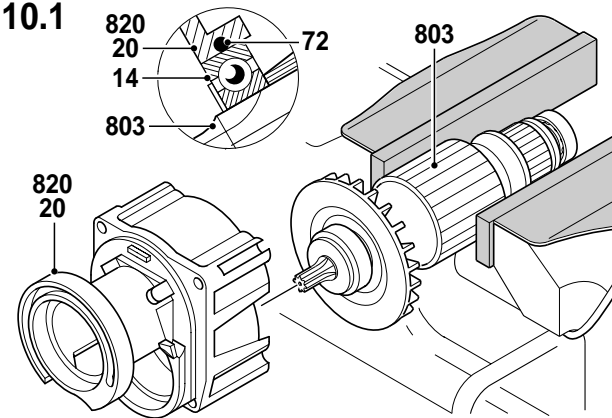

10.2

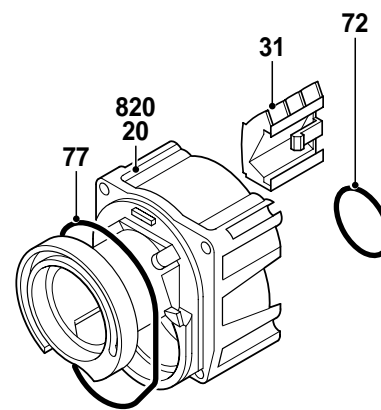

10.3

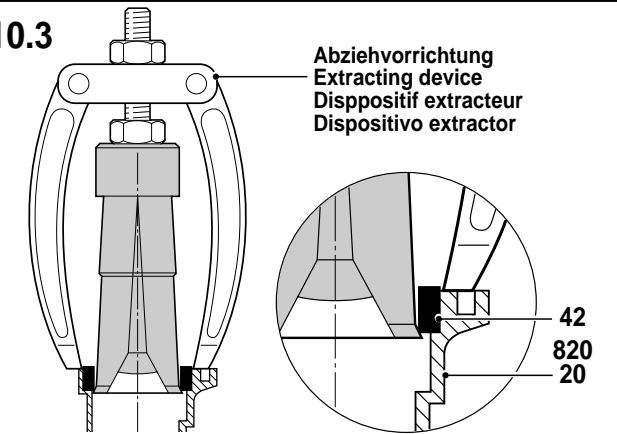

11.

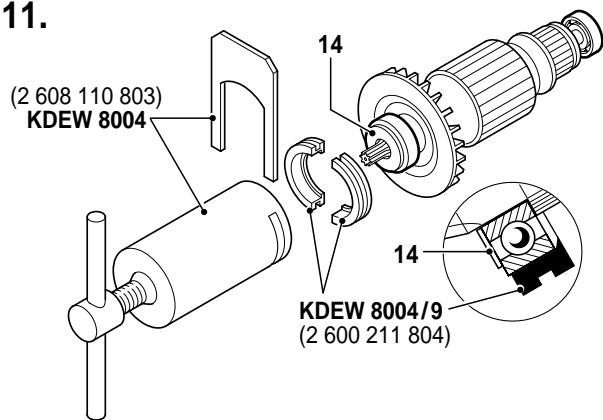

11.1

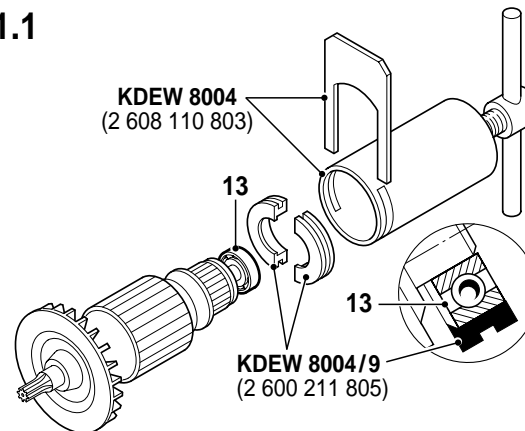

12.

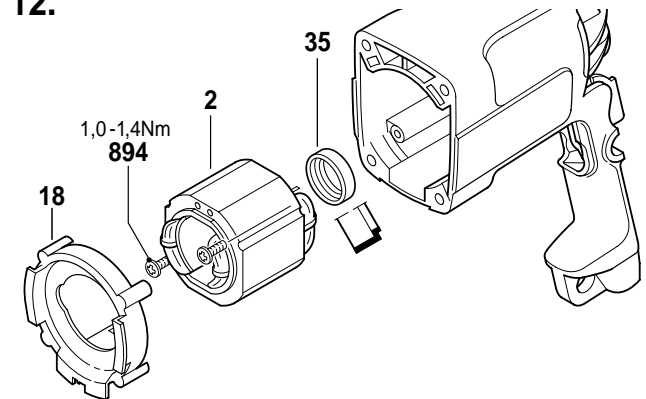

Zusammenbau

Montage nach Explosionszeichnung und diesem Instandsetzungshinweis.

Alle Teile sind gereinigt, abgenutzt und beschädigte Teile werden ersetzt.

Nur Original-Ersatzteile verwenden.

Zähne aller Zahnräder mit Fett **1 615 430 002** bestreichen.

Bitte Schmierhinweise beachten!

Assembly

Assembly using explosion drawings and these repair instructions!

Clean all parts, replace worn-out and damaged parts.

Use only original spare parts!

Grease all gear teeth **1 615 430 002**.

Please note lubrication instructions!

Montage

Le montage s'effectue selon la vue éclatée et les instructions de réparation suivantes.

Toutes les pièces sont nettoyées, les pièces usées ou endommagées doivent être remplacées par des nouvelles. Pour le remplacement de pièces, n'utiliser que des pièces d'origine.

Les dents graisser **1 615 430 002**.

Respecter les instructions de graissage!

Montaje

Realizar el montaje conforme a los dibujos en perspectiva y a estas instrucciones de reparación.

Todas las piezas deben estar limpias. Las piezas desgastadas o danadas deben reemplazarse por piezas nuevas. Utilizar solamente piezas de repuesto originales.

Dientes engrasar **1 615 430 002**.

Observar las instrucciones de lubricación!

21.

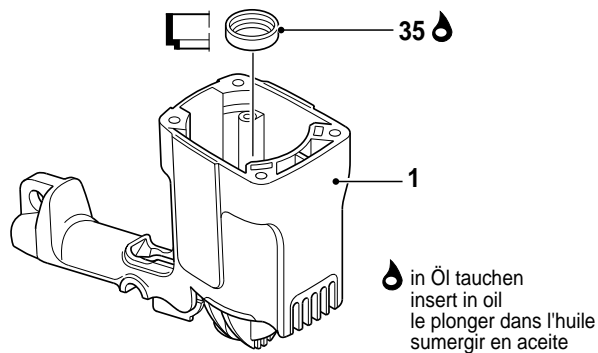

21.1

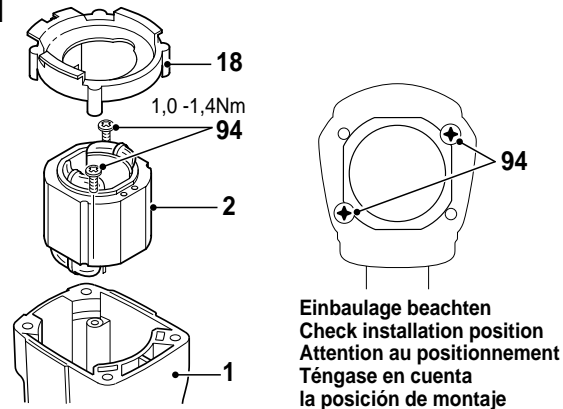

22.

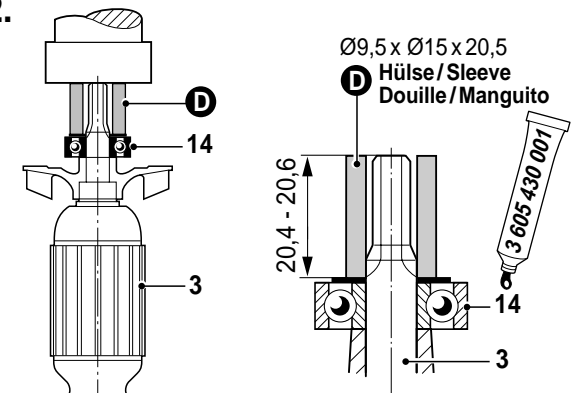

22.1

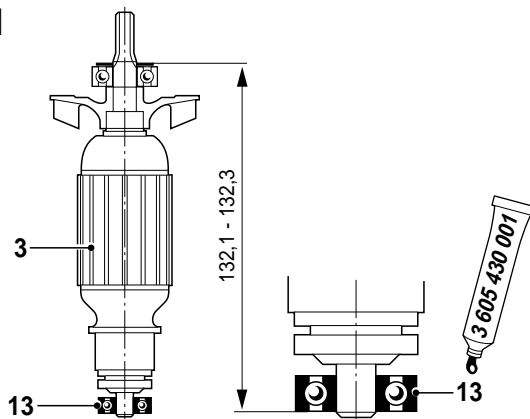

23.

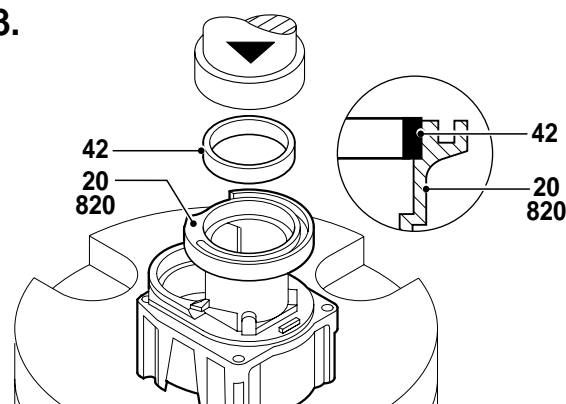

23.1

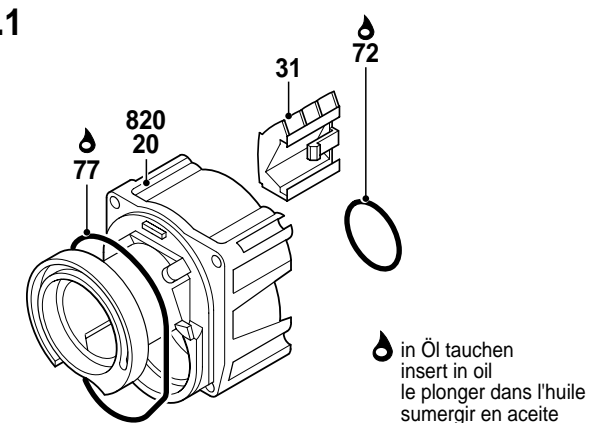

23.2

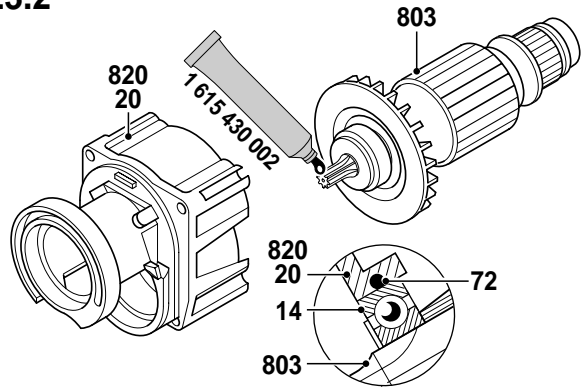

23.3

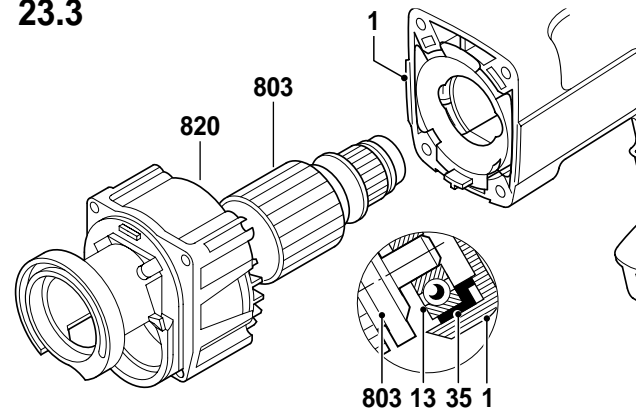

23.4

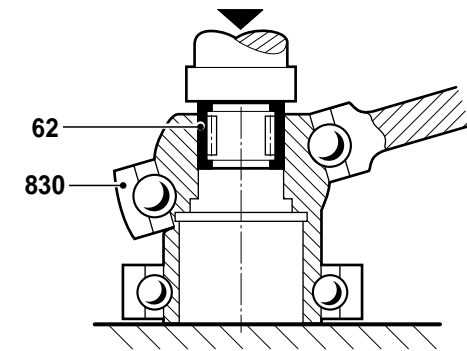

23.5

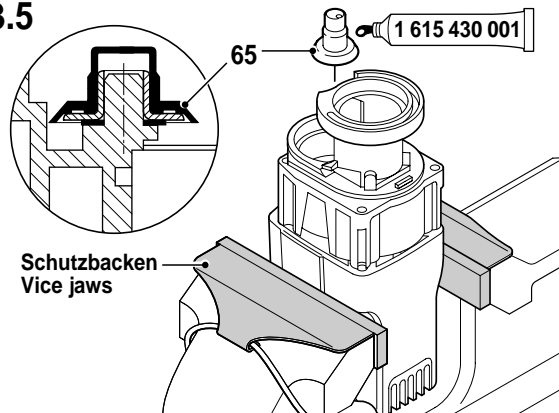

23.6

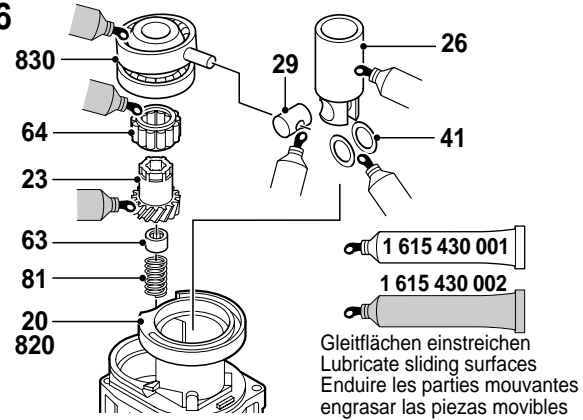

23.7

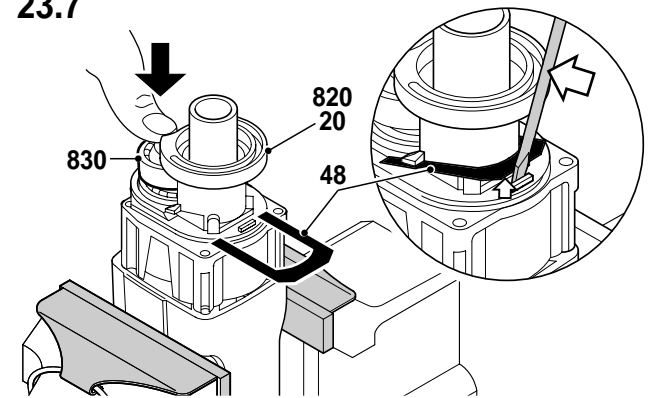

24.

 in Öl tauchen
 insert in oil
 le plonger dans l'huile
 sumergir en aceite

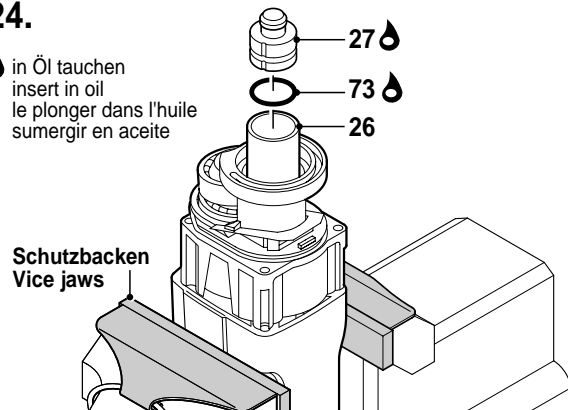

24.1

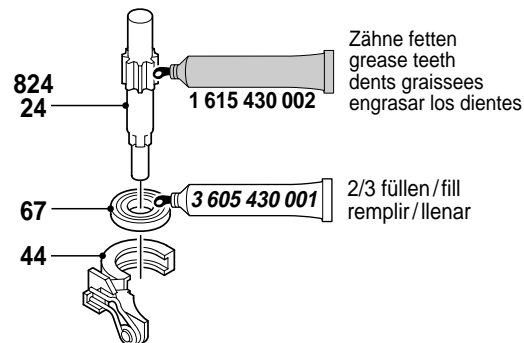

24.2

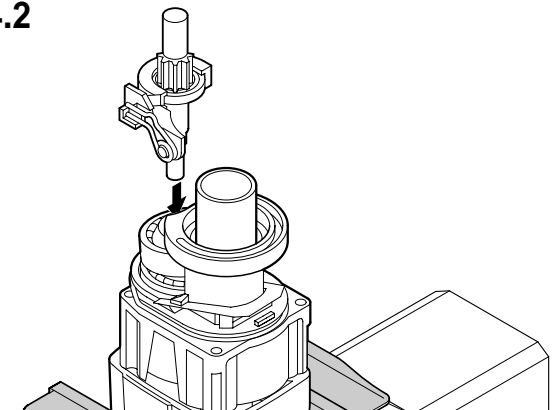

25.

Neue Ausführung
New execution
Nueva ejecución
Nouvelle exécution

in Öl tauchen
insert in oil
le plonger dans l'huile
sumergir en aceite

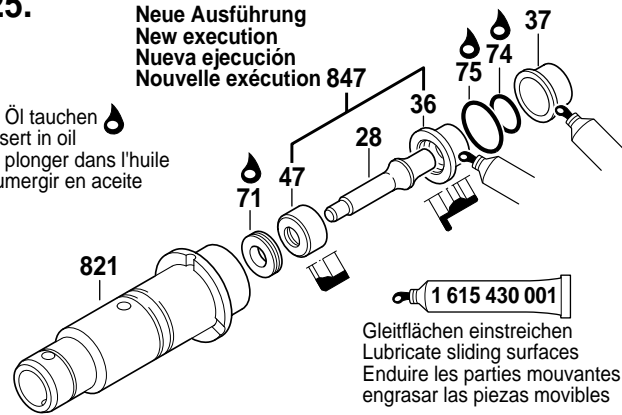

Gleitflächen einstreichen
Lubricate sliding surfaces
Enduire les parties mouvantes
engrasar las piezas móviles

25.1

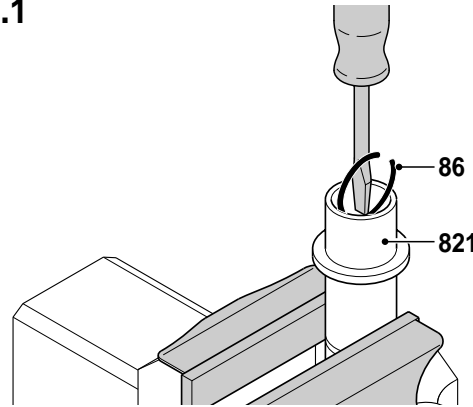

25.2

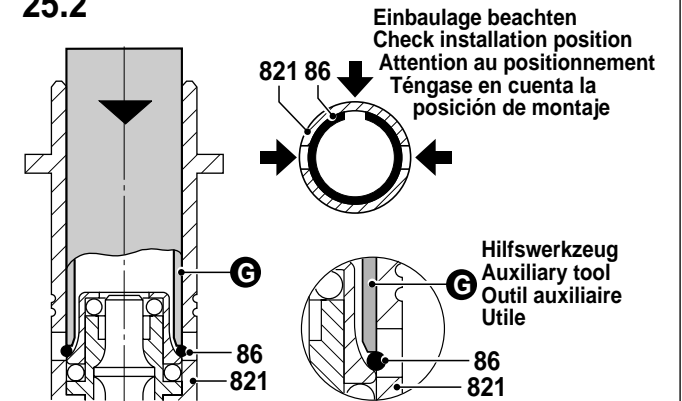

25.3

Hilfswerkzeug
Auxiliary tool
Outil auxiliaire
Utile

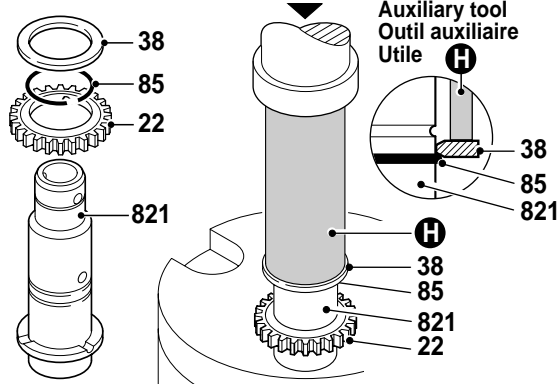

25.4

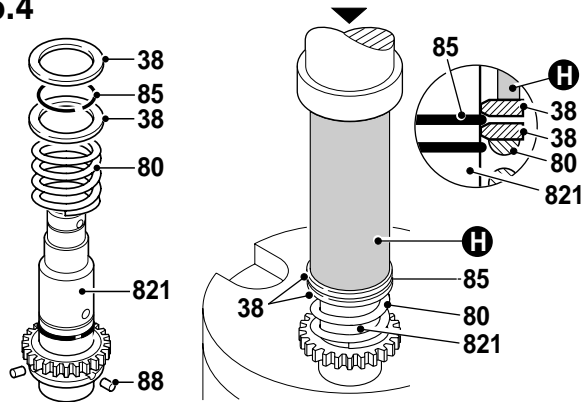

25.5

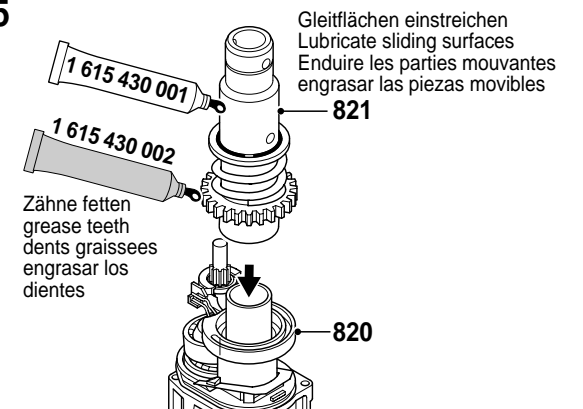

26.

Montagehülse
Mounting sleeve
Douille de montage
Casquillo de montaje

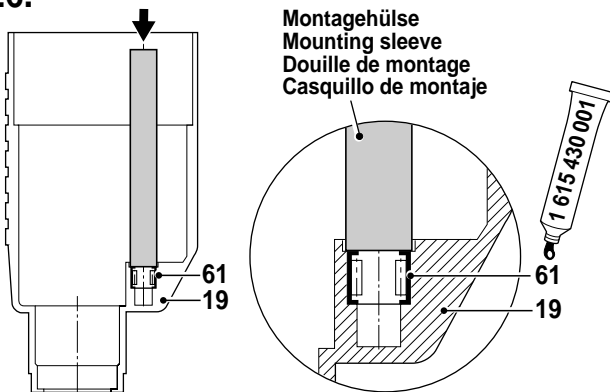

26.1

Montagehülse
Mounting sleeve
Douille de montage
Casquillo de montaje

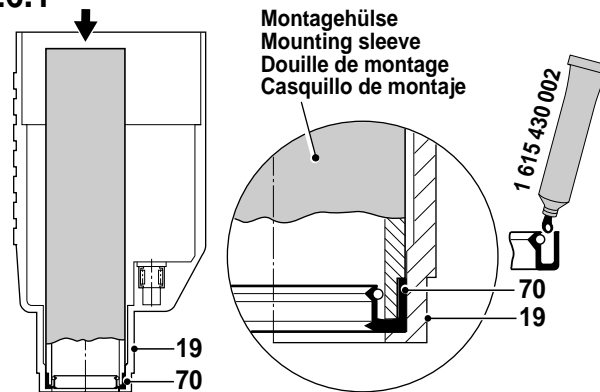

26.2

Montagehülse
Mounting sleeve
Douille de montage
Casquillo de montaje

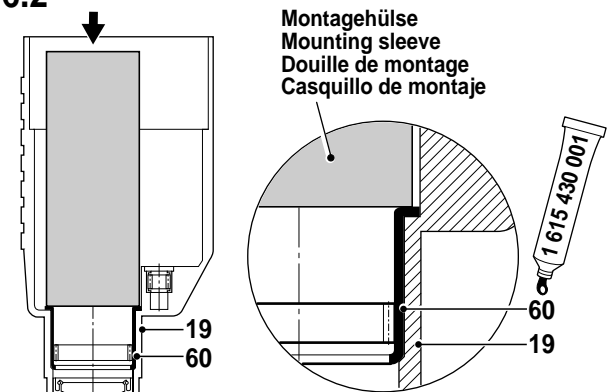

26.3

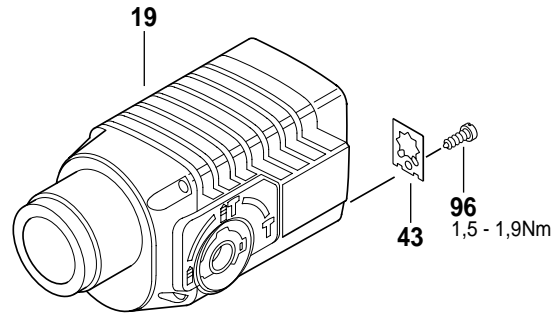

26.4

Teile fetten (45g); Rest in Getrieberaum Pos. 19.
Grease the parts (45g); rest into gear compartment pos. 19.
Graisser les pieces (45g); la graisse restante dans le compartiment d'engrenage 19.
Engrasar las piezas (45g); resto en el compartimento del engranaje pos. 19.

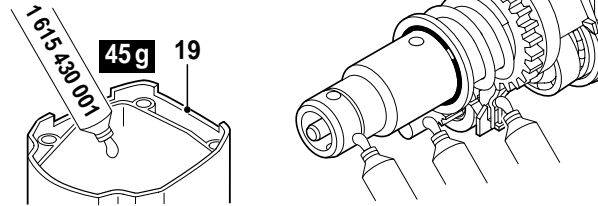

26.5

neu / nouveau
new / nuevo
Torx

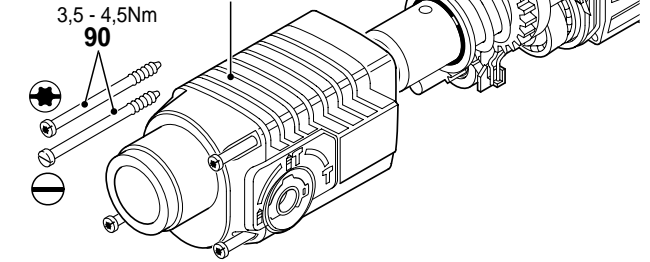

27.

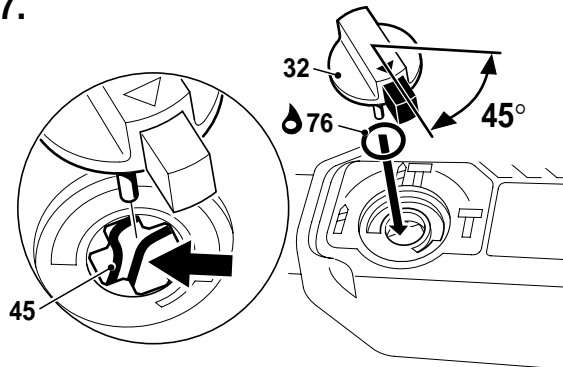

27.1

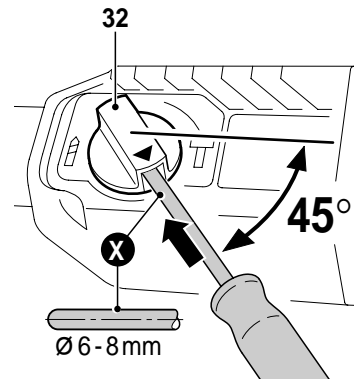

27.2

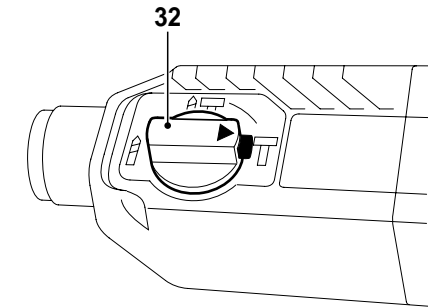

28.

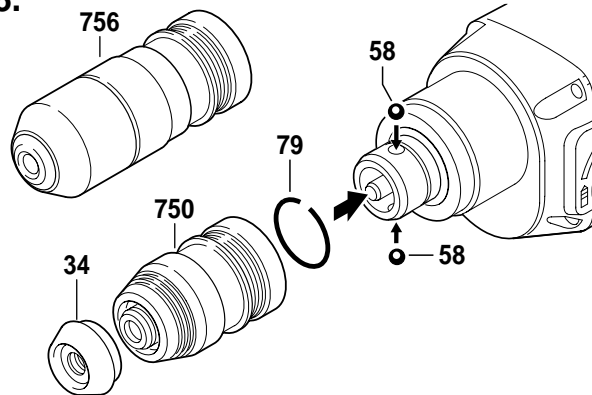

29.

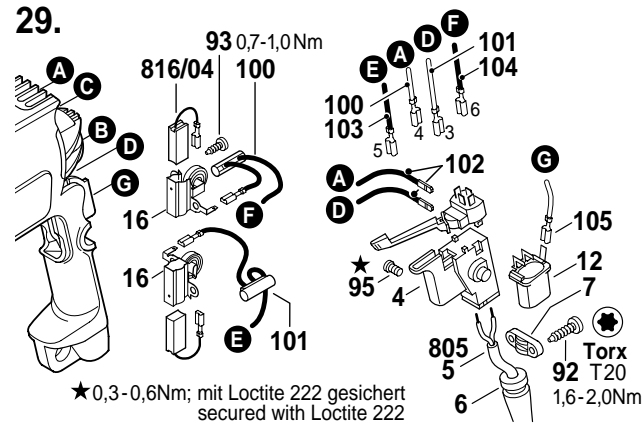

29.1

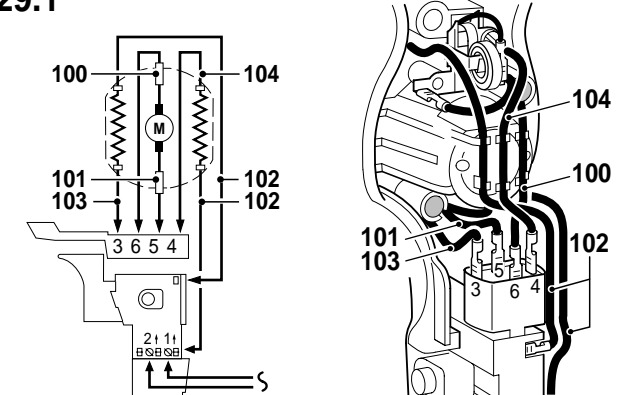

30.

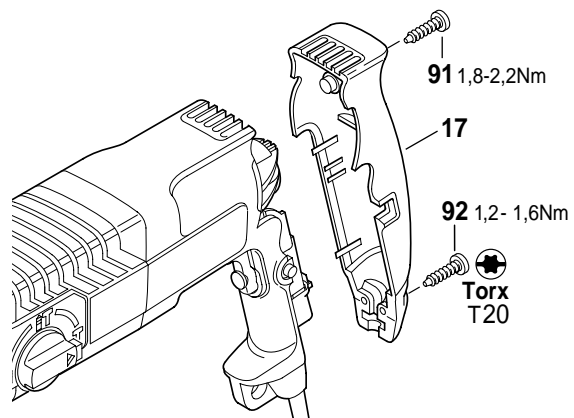

31.

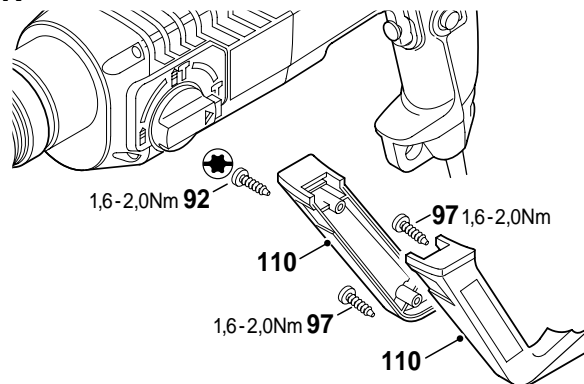

32.

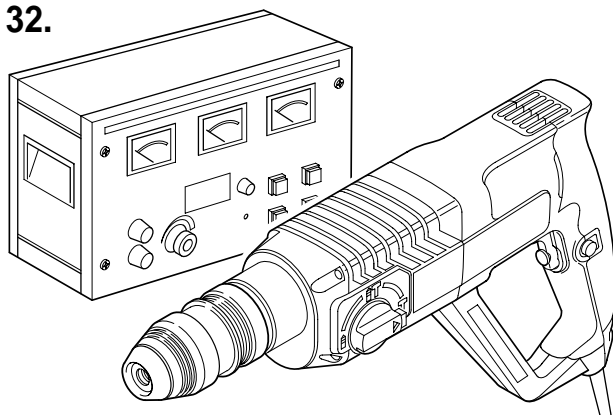

32. Hochspannungsprüfung durchführen.
Beachten:
Die Sicherheitsvorschriften nach DIN, VDE, CEE, AFNOR und weitere in den einzelnen Ländern gültigen Vorschriften sind einzuhalten.

32. Effectuer un contrôle à haute tension.
Attention:
Respecter les instructions de sécurité selon DIN, VDE, CEE, AFNOR et les autres instructions valables dans les pays respectifs.

32. Carry out power supply check.
Attention:
Safety regulations according to DIN, VDE, CEE, AFNOR and further regulations applicable in individual countries must be observed.

32. Efectuar la prueba de alta tensión.
Atención:
Atenerse a las prescripciones de seguridad según DIN, VDE, CEE, AFNOR y a las prescripciones adicionales específicas que pudieran existir en los respectivos países.

33.

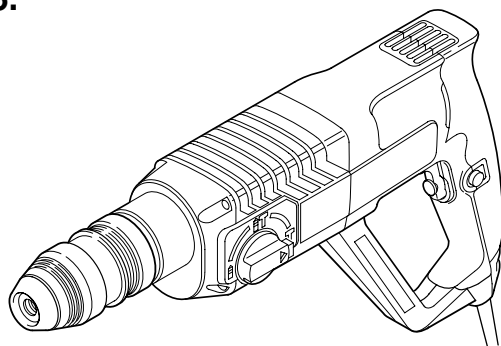

33. Probelauf, Schlagtest, elektrische und mechanische Prüfung durchführen.

33. Marche à titre d'essai, contrôle de frappe et depercage, effectuer un contrôle mécanique et électrique.

33. Perform test run, impact test, electrical and mechanical check-up.

33. Realizar un control funcional, una prueba de taladrado con y sin percusión y los ensayos eléctricos y mecánicos correspondientes.

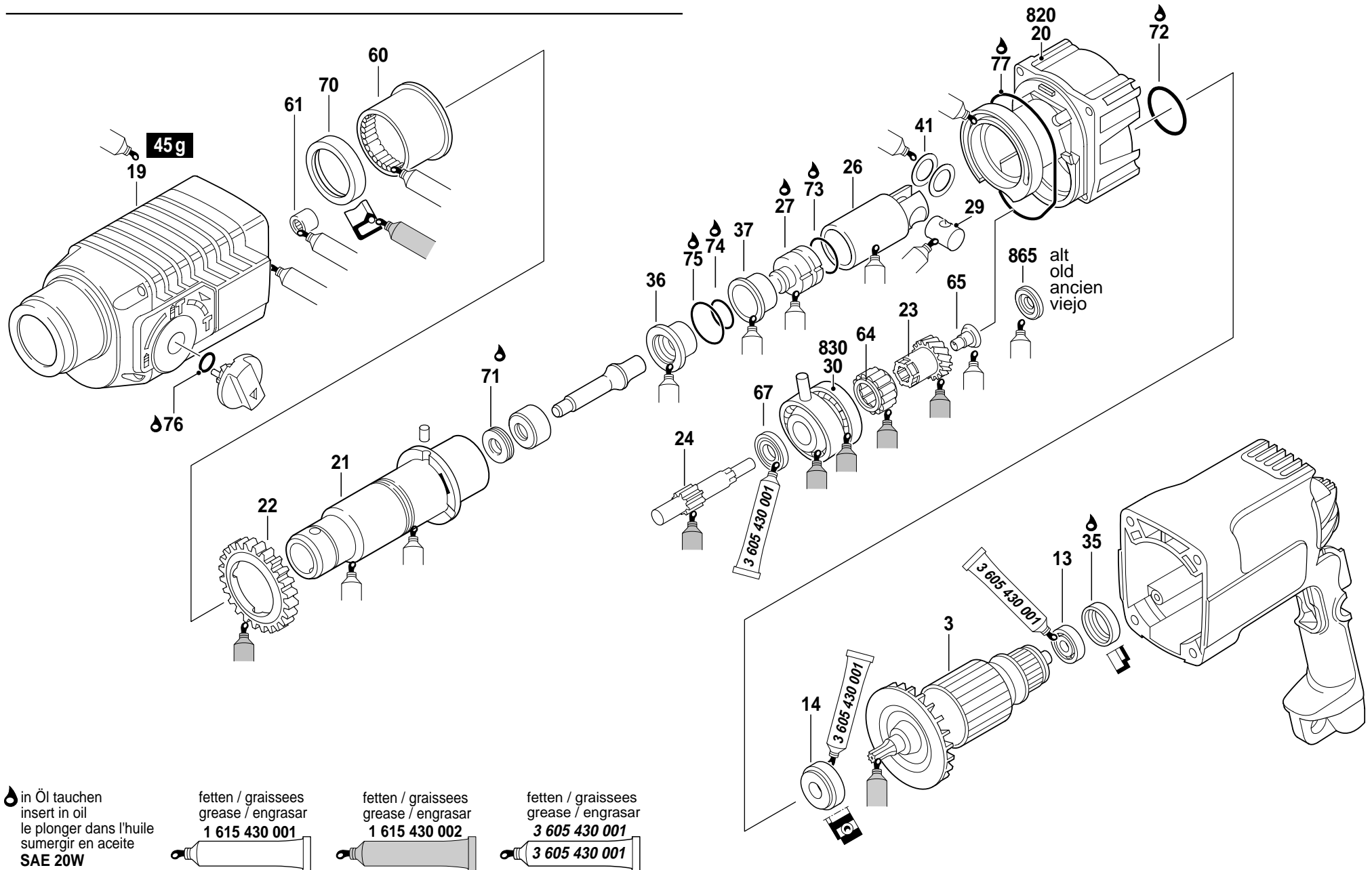

**Schmierung
Lubrication
Lubrification
Lubricacion**

0 603 326 7 .. = PBH 240 RE

Stand / Issue: 99-07

Änderungen vorbehalten
Modifications reserved
Modifications réservées
Salvo modificaciones

Schmierstelle Lubrication point Point de lubrification Punto de lubricacion	Fig./Pos.	Schmierstoff Fett Öl Lubricant grease oil Lubrifiant graisse huile Lubricante grasa aceite	Mengen Quantity Quantite Cantidad	Schmiervorschrift Lubricating instructions Indications de graissage Instrucciones de lubricacion
Getriebe und Schlagwerkraum Gear and percussion mechanism space Carter de l' engrenage et boîtier du système de frappe Engranaje y parte de engranaje		1 615 430 001	45-50 g	Teile fetten, Rest in Getrieberaum grease the parts, rest into gear compartment graisser les pieces, la graisse restante dans le compartiment d'engrenage engrasar las piezas, resto en el compartimento del engranaje
Gleitende Teile Sliding parts Pieces glissantes Piezas deslizantes	19 21 26; 29 36; 37			Gleitflächen einstreichen lubricate sliding surfaces enduire les parties mouvantes engrasar las piezas móviles
Nadelhülse Needle bushing Douille à aiguilles Casquillo de agujas	60 61		*	fetten grease graisser engrasar
Gleitlager Friction bearing Palier-glisser Cojinete de deslizamiento	65		*	fetten grease graisser engrasar
Ritzel; Zahnrad Pinion; Toothed gear Pignon; Roue d'engrenage Pinon; Rueda de engranaje	3 22 23 24	1 615 430 002		Zähne füllen, fetten Fill teeth, grease remplir les dents, graisser Llenar dientes, engrasar
Antriebslager Drive end shield Flasque cote entrainement Tapa lado accionamiento	30			Teile fetten grease the parts graisser les pieces engrasar las piezas
Nadelkranz Needle-roller assembly Couronne d'aiguilles Corona de agujas	64		*	fetten grease graisser engrasar
Wellendichtring Shaft sealing ring Joint à levres Reten para arboles	70			Hohlraum zwischen Dichtlippen füllen fill cavity between sealing lips remplir cavite entre les levres du joint llenar el vacio entre los labios del reten

Schmierstelle Lubrication point Point de lubrification Punto de lubricacion	Fig./Pos.	Schmierstoff Fett Öl Lubricant grease oil Lubrifiant graisse huile Lubricante grasa aceite	Mengen Quantity Quantite Cantidad	Schmierstoffvorschrift Lubricating instructions Indications de graissage Instrucciones de lubricacion
Rillenkugellager Deep-groove ball bearing Roulement à billes rigide Rodamiento radial rígido	13 14 67	3 605 430 001	*	2/3 füllen fill remplir llenar
O-Ring O-ring joint torique antillo toroidal	71; 72 73; 74 75; 76 77	SAE 20 W Mineralöl, handelsüblich Mineral oil, standard / Huile minerale en vente dans le commerc Aceite usual en el comercio		in Öl tauchen; 3 h in Öl legen insert in oil; lay in oil for 3 h le plonger dans l'huile; le poser 3 h sumergir en aceite; poner 3 h en aceite
Teile Parts Pieces Piezas	27 35			einölen; in Öl tauchen oil; dip in oil huiler le plonger dans l'huile engrasar con aceite; sumergir en aceite

*sofern Lager ungefettet
if bearing is unlubricated
si roulement n'est pas graisse
en caso de que el rodamiento
esta son grasa

Prüfwerte
Testing values
Valeurs de vérification
Valores de control

0 603 326 7 .. = PBH 240 RE

Stand / Issue: **99-07**

Spannung Voltage Voltage Voltaje	Leerlauf no-load running marche à vide marcha en vacío		Widerstand (20°C/ 68°F) resistance résistance resistencia		Zulässige Übertemperatur im Leerlauf admissible over temperature at no-load élévation admissible de température à vide sobrettemperatura admisible en vacío		
V Typ	A	Spindeldrehzahl speed of spindle vitesse de la broche velocidad del husillo 1/min - rpm - t/mn - rpm Stufe	des Ankers of rotor du rotor del rotor Ω	einer Feldspule of one stator coil d'une bobine du stator de una bobina del estator Ω	Motor motor moteur motor °C	Getriebe gear engrenage engrenaje °C	Arbeitsspindel spindle broche husillo °C
100	2.805 - 4.995	849 - 1.201 0 - 0	0.734 - 0.948	0.662 - 0.868	15	25	35
110	2.135 - 4.465	849 - 1.201 0 - 0	0.734 - 0.948	0.823 - 1.067	15	25	35
115	2.635 - 3.965	849 - 1.201 0 - 0	0.937 - 1.214	0.681 - 0.889	15	25	35
230	1.264 - 2.186	849 - 1.201 0 - 0	3.804 - 4.825	3.313 - 4.198	15	25	35
240	1.205 - 2.595	849 - 1.201 0 - 0	4.505 - 5.705	3.966 - 4.984	15	25	35

Bemerkung: Überrasstmoment der Kupplung 14 -18 Nm. Bei nicht erreichen von 14 Nm, Kupplung ersetzen.
 For your notice: Slipping point of clutch 14 -18 Nm. Under 14 Nm replace clutch.

Kollektor-Mindestdurchmesser: Minimum diameter of commutator: Diamètre minimum du collecteur: Diámetro mínimo del colector:	mm	Kohlebürsten-Mindestlänge: Minimum length of brushes: Longueur minimale des balais: Longitud mínima de las escobillas:	= X	Abschaltkohlen cut-off brushes charbon rupteur carbón de desconexión
--	----	---	-----	---

Änderungen vorbehalten

Unsere Erzeugnisse werden stets dem neuesten technischen Stand angepaßt. Deshalb müssen wir uns Änderungen von technischen Daten vorbehalten.

Modifications

Our products are constantly modified to meet new technical standards. We there-fore reserve the right to alter data and specifications without prior notice.

Modifications

Nos produits sont continuellement adaptés aux dernières nouveautés techniques et les dates sont données sous réserve de changement.

Modificaciones

Nuestros fabricados van siendo adaptados constantemente a las últimas conquistas técnicas. Por ello, tenemos que reservarnos el derecho de introducir modificaciones en los datos técnicos.